

F2000AT Fresh Cut Apple System

Cutting System



F2000AT Fresh Cut Apple System - wedge/core, controlled treatment, drainage belt, optional air knife

The F2000AT is a combination wedger/corer and treatment system for fresh cut apples. The compact system is capable of cutting and treating 40 apples per minute. The cut wedges fall directly into the treatment bath, while the cores pass through to the waste chute. Residence time in the treatment bath is variable from 45 seconds to two minutes. Optional pre-wash feed trough and discharge air knife are available.

Ask us about our high capacity lines up to 2500 lbs/hr.

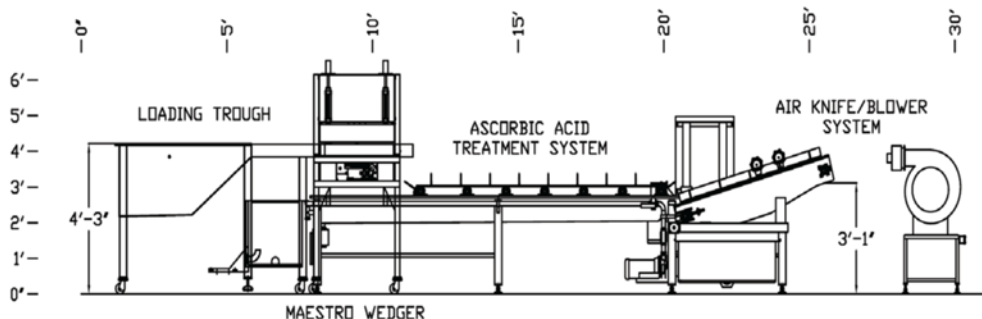

North Star Engineered Products

Model F2000AT

SPECIFICATIONS

Model F200AT	Capacity / Dimensions
Capacity	Up to 40 pieces / minute (900 lbs. / hr.)
Width	28 inches
Length	93 inches
Height	72 inches
Utilities	230V / 60 Hz / 3 phase 460V / 60 Hz / 3 phase
Tank Capacity	Recirculation tank – 13 gal. Treatment tank – 10 gal.
Total Weight	600 lbs.

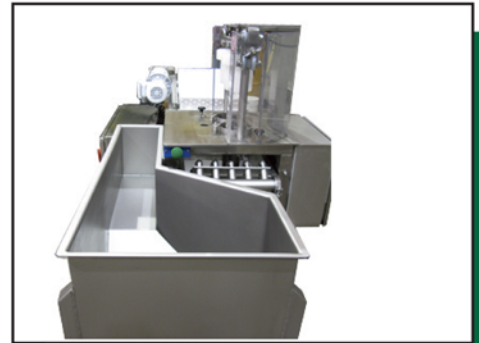

Pre-wash feed trough



Air knife option

KEY FEATURES

- ▶ Wedges drop directly into treatment tank
- ▶ Cores are separated and drop into waste chute
- ▶ Compact size fits most work environments
- ▶ Cam action - constant slicing pressure
- ▶ Adjustable residence time - 45 seconds to 2 minutes
- ▶ Adjustable pump speed
- ▶ Adjustable discharge belt speed

OPTIONS

- ▶ Blade and plunger options
 - Wedge - 4, 8, 12, 16 segments
 - Core Size - 25, 30, 35mm
- ▶ Air knife - over discharge belt
- ▶ Pre-wash feed trough

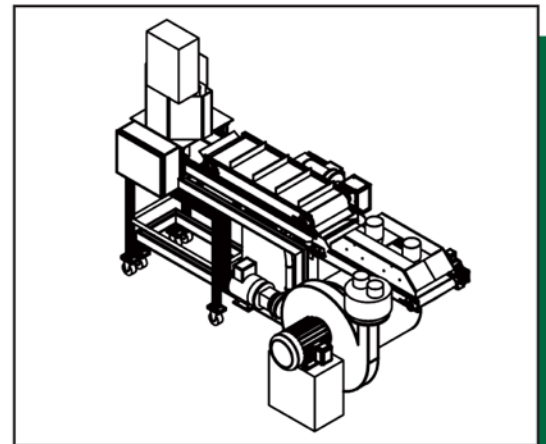

F2000AT capable of producing 900 lbs fresh cut apples / hr.



North Star Engineered Products
28905 Glenwood Road • P.O. Box 1141
Perrysburg, OH 43552-1141 USA

Phone: 419.726.2645 • Fax: 419.726.8583
E-Mail: sales@northstarengineered.com

A Division of Glassline Corporation