

# **Operations Manual**

Model FP-90 / FP-90A

NORTH STAR ENGINEERED PRODUCTS



NORTH STAR ENGINEERED PRODUCTS

PO BOX 1141

PERRYSBURG, OH 43552

P. 419-726-2645

F. 419-726-8583

[sales@northstarengineered.com](mailto:sales@northstarengineered.com)

**TEST & INSPECTION SHEET**

SOLD TO \_\_\_\_\_

***MACHINE***

\_\_\_\_\_ MODEL \_\_\_\_\_ NSEP ORDER #  
\_\_\_\_\_ SERIAL NUMBER \_\_\_\_\_ DATE

***MOTOR & CONTROLS***

\_\_\_\_\_ INVERTER S/N  
\_\_\_\_\_ MOTOR VOLTAGE \_\_\_\_\_ CONTROL VOLTAGE  
\_\_\_\_\_ MOTOR MFG \_\_\_\_\_ INCOMING POWER  
\_\_\_\_\_ MOTOR S/N \_\_\_\_\_ MOTOR HORSEPOWER  
\_\_\_\_\_ MOTOR RPM \_\_\_\_\_ MOTOR PULLEY SIZE  
\_\_\_\_\_ MOTOR CODE NO. \_\_\_\_\_ DRIVE BELT

***DRIVE UNIT AND BASKET***

\_\_\_\_\_ UNIT PULLEY SIZE  
\_\_\_\_\_ BASKET RPM (MAXIMUM)  
\_\_\_\_\_ BASKET WEIGHT CAPACITY

***TESTING RESULTS***

\_\_\_\_\_ PROCEDURE NUMBER USED  
\_\_\_\_\_ STARTING AMPS  
\_\_\_\_\_ RUNNING AMPS  
\_\_\_\_\_ BRAKING TIME  
\_\_\_\_\_ INSPECTORS INITIALS

NORTH STAR ENGINEERED PRODUCTS  
28905 GLENWOOD RD  
PERRYSBURG, OHIO 43551

FORM Z-00860

REV C 8/14/06

# TEST & INSPECTION SHEET

SOLD TO \_\_\_\_\_

## ***MACHINE***

\_\_\_\_\_ MODEL \_\_\_\_\_ NSEP ORDER #  
\_\_\_\_\_ SERIAL NUMBER \_\_\_\_\_ DATE

## ***MOTOR & CONTROLS***

\_\_\_\_\_ INVERTER S/N  
\_\_\_\_\_ MOTOR VOLTAGE \_\_\_\_\_ CONTROL VOLTAGE  
\_\_\_\_\_ MOTOR MFG \_\_\_\_\_ INCOMING POWER  
\_\_\_\_\_ MOTOR S/N \_\_\_\_\_ MOTOR HORSEPOWER  
\_\_\_\_\_ MOTOR RPM \_\_\_\_\_ MOTOR PULLEY SIZE  
\_\_\_\_\_ MOTOR CODE NO. \_\_\_\_\_ DRIVE BELT

## ***DRIVE UNIT AND BASKET***

\_\_\_\_\_ UNIT PULLEY SIZE  
\_\_\_\_\_ BASKET RPM (MAXIMUM)  
\_\_\_\_\_ BASKET WEIGHT CAPACITY

## ***TESTING RESULTS***

\_\_\_\_\_ PROCEDURE NUMBER USED  
\_\_\_\_\_ STARTING AMPS  
\_\_\_\_\_ RUNNING AMPS  
\_\_\_\_\_ BRAKING TIME  
\_\_\_\_\_ INSPECTORS INITIALS

NORTH STAR ENGINEERED PRODUCTS  
28905 GLENWOOD ROAD  
PERRYSBURG OHIO 43551

FORM Z-00860

REV C 8/14/06

TEST RESULTS #4

205TX, 305TX, 605TX, 805TX, FP305, FP605, FP805, FP90, FP-95, FP900, GP-100,  
& GP-130 CENTRIFUGES

S.O. # \_\_\_\_\_

CUSTOMER \_\_\_\_\_

SERIAL # \_\_\_\_\_

1. CYCLE TEST MACHINE 15 TIMES WITH MAXIMUM LOAD OF BASKET  
CAPACITY, INCLUSIVE SAFETY EVALUATION. CHECKED BY: \_\_\_\_\_

2. FILL BASKET WITH WATER AND CHECK FOR SEAM AND LID LEAKS.  
CHECKED BY: \_\_\_\_\_

3. 3 OF THE 15 TEST CYCLES RECORD CYCLE TIME.

\_\_\_\_\_ MINS. & \_\_\_\_\_ SEC.

\_\_\_\_\_ MINS. & \_\_\_\_\_ SEC.

\_\_\_\_\_ MINS. & \_\_\_\_\_ SEC.

4. WELD COSMETICS CHECKED BY: \_\_\_\_\_

5. VIBRATION TEST CONTROL BOX-SIDE \_\_\_\_\_ IN./SEC.

CONTROL BOX-TOP \_\_\_\_\_ IN./SEC.

6. WEIGHT CAPACITY ETCHED ON BASKET. \_\_\_\_\_ LB.

7. SERIAL # OF FP90 BASKET(S) \_\_\_\_\_

# OF DOLLIES \_\_\_\_\_

# OF YOKES \_\_\_\_\_

8. COMMENTS ON MACHINE AND  
OPTIONS: \_\_\_\_\_

9. INSPECTOR'S NAME: \_\_\_\_\_

TEST RESULTS #4

205TX, 305TX, 605TX, 805TX, FP305, FP605, FP805, FP90, FP-95, FP900, GP-100,  
& GP-130 CENTRIFUGES

S.O. # \_\_\_\_\_

CUSTOMER \_\_\_\_\_

SERIAL # \_\_\_\_\_

1. CYCLE TEST MACHINE 15 TIMES WITH MAXIMUM LOAD OF BASKET  
CAPACITY, INCLUSIVE SAFETY EVALUATION. CHECKED BY: \_\_\_\_\_

2. FILL BASKET WITH WATER AND CHECK FOR SEAM AND LID LEAKS.  
CHECKED BY: \_\_\_\_\_

3. 3 OF THE 15 TEST CYCLES RECORD CYCLE TIME.

\_\_\_\_\_ MINS. & \_\_\_\_\_ SEC.

\_\_\_\_\_ MINS. & \_\_\_\_\_ SEC.

\_\_\_\_\_ MINS. & \_\_\_\_\_ SEC.

4. WELD COSMETICS CHECKED BY: \_\_\_\_\_

5. VIBRATION TEST CONTROL BOX-SIDE \_\_\_\_\_ IN./SEC.

CONTROL BOX-TOP \_\_\_\_\_ IN./SEC.

6. WEIGHT CAPACITY ETCHED ON BASKET. \_\_\_\_\_ LB.

7. SERIAL # OF FP90 BASKET(S) \_\_\_\_\_

# OF DOLLIES \_\_\_\_\_

# OF YOKES \_\_\_\_\_

8. COMMENTS ON MACHINE AND  
OPTIONS: \_\_\_\_\_

9. INSPECTOR'S NAME: \_\_\_\_\_

This manual is for the fluid drive FP-90 with digital timer.

## **TABLE OF CONTENTS**

FOUR IMPORTANT POINTS.....	7
PREPARATION FOR USE AND INSTALLATION INSTRUCTIONS.....	8
UNPACKING INSTRUCTIONS:.....	8
MOUNTING PRECAUTIONS:.....	9
OPERATING INSTRUCTIONS.....	10
A. LOADING: FP90.....	10
B. OPERATION:.....	10
C. EMERGENCY STOP:.....	10
D. SAFETY OPERATION:.....	10
TOOLS.....	11
WARRANTY.....	11
PREVENTIVE MAINTENANCE.....	12
SUMMARY OF SAFETY INFORMATION.....	13
SAFETY TESTS:.....	14
SERVICE MANUAL FOR FP90.....	16
SERVICE MANUAL TABLE OF CONTENTS.....	16
ELECTRICAL CONTROL PANEL PARTS.....	27
FP90 DRIVE UNIT ASSEMBLY AND DISASSEMBLY.....	28
3210SS DRIVE UNIT ASSEMBLY.....	30
3210 DRIVE UNIT BREAKDOWN & PARTS.....	31
INSTRUCTIONS FOR ADJUSTING BRAKE.....	32
AIR BRAKE ASSEMBLY & PARTS.....	33
TROUBLE SHOOTING GUIDE - MODEL FP90.....	35
PARTS LIST.....	38
MOTOR ASSEMBLIES AND ASSOCIATED PARTS FOR FP90.....	39
GLOSSARY.....	40
SCHEMATIC DIAGRAM.....	41
WIRING DIAGRAM.....	42
LIMITED WARRANTY.....	E

**rror! Bookmark not defined.**

## **FOUR IMPORTANT POINTS**

- 1. REMOVE ALL SUPPORTS FROM (UNDER AND AROUND) BASKET BEFORE STARTING MACHINE. WHEN REPLACING BASKET IN THE MACHINE, SET IT GENTLY DOWN ON SHAFT AND ROTATE THE BASKET UNTIL IT DROPS DOWN AND SEATS. AN IMPROPERLY INSTALLED BASKET CAN RESULT IN DAMAGE TO THE CENTER POST AND/OR THE GYRO BALL.**
- 2. DO NOT RESTRICT OR REDUCE DRAIN IN ANY WAY. DO NOT HOOK UP MACHINE ON THE SAME DRAIN LINE AS OTHER EQUIPMENT BECAUSE A BACK WASH MAY RESULT.**
- 3. THE (ELECTRIC) BRAKE ON YOUR NSEP MACHINE WILL REQUIRE SEVERAL ADJUSTMENTS IN THE FIRST 30 DAYS OF OPERATION. IT IS IMPORTANT TO KEEP THE BRAKE PROPERLY ADJUSTED.**

## **PREPARATION FOR USE AND INSTALLATION INSTRUCTIONS**

### UNPACKING INSTRUCTIONS:

- A. Never top load centrifuge-use fork lift or pallet jack on bottom skid only.
- B. Never stack or place anything on top of centrifuge.
- C. Examine exterior of machine for any sign of damage, and note on bill of lading.
  - 1. Scratched or damaged parts of machine.
  - 2. Broken pallet.
- D. Remove outer shipping shrink wrap.
  - 1. Remove any cardboard attached to machine.
  - 2. Basket may be removed at this time as per step E at this point, (the machine will be considerably lighter and easier to move).
  - 3. Maneuver machine near desired location.
  - 4. Remove machine from shipping pallet by removing bolts through legs and sliding or walking machine off the pallet. CAUTION: machine weighs approximately 1200#, (do not use electrical boxes, lid hinge frame, or curb assembly to lift the machine, lift with skirt or legs).
- E. Open lid of centrifuge fully and remove perforated basket. See step A of service manual, (CAUTION: basket weighs 300#).
  - 1. It is best to remove basket from machine with a overhead hoist. Lift basket straight up and completely out of machine and set aside.
  - 2. Remove all cardboard packing inside curb assembly.
  - 3. Inspect and make certain that the basketball is lightly greased with medium weight lithium grease. Do not reinstall basket until machine is bolted in place.
- F. Inspect exterior of machine for damage.
  - 1. Dents and scratches in lid, curb assembly or control box.
  - 2. Inspect motor hanger for cracks in casting that may occur if the machine was dropped during shipping.
  - 3. Remove 2291SS control panel, (see step N of service manual) and inspect for loose or cracked parts).
- G. Installation:
  - 1. Maneuver machine to its desired location. Enough room should be allowed behind machine to give adequate clearance for service work.
  - 2. Mark location of holes through the legs.
  - 3. Remove the machine and drill mounting holes (recommend using 2-1/2" X 1/2" lag bolts and lead anchors into concrete). Mounting hardware is not provided.

4. Replace machine and loosely bolt through the legs.
5. Shim the machine until it is level.
6. Tighten all mounting bolts.
7. Gently replace basket assembly as per step B of service manual. Cardboard packing should have been removed from under and around basket already. If not, remove the cardboard now before replacing basket.
8. Turn & rock basket slightly to be sure basket is properly seated on the hex basketball.

**MOUNTING PRECAUTIONS:**

- A. Never use resilient pads under legs - this will increase vibration.
- B. Mount machine on a level surface.
- C. If installed on a wooden floor, and excessive vibration is felt, install a 4 X 4 jack under each leg from the floor below.
- D. Mounting bolts should be checked periodically for tightness.

## **OPERATING INSTRUCTIONS**

### A. Loading: FP90

1. Never load basket with more than dry weight capacity or above top of basket.
2. Load evenly with a balanced load, do not allow anything to hang over the top of basket.
3. Loads should remain a few inches below the inside of the basket top.

### B. Operation:

1. The machine is equipped with a timer, with a range of 0-10 minutes (longer timers optional). Locate timer and turn the knob, setting the small black hand at the desired length of the cycle. (Minimum of a 4 minute cycle.) Outside timer is located on the side of the control box (2290SS).

To set the digital timer, push the SET button. Adjust the time by pushing the individual arrow buttons (▲). Push the ENT key to accept the time.

2. Lift lid, load machine evenly, close lid completely, pull out emergency stop button (if depressed), press green start button.
3. Lid lock light (in stop button) will come on, lid will lock, and machine will run for pre-set time. Do not try to open the lid while stop button is lit.
4. At the end of the cycle, the centrifuge will automatically stop. Open lid only after stop button light has gone out.

### C. Emergency stop:

This machine is equipped with a push-pull emergency stop button. If the machine vibrates excessively or becomes noisy during the cycle, or if it is obvious that something is between the basket and the curb, push the emergency stop button. Wait until the red signal light goes out (light located in center of stop button) before attempting to open the lid.

Rebalance the load, checking to make certain that nothing has dropped between the basket and curb, or investigate and correct the cause of noise or vibration. To re-start, close the lid, pull out the emergency stop button and push the start button.

### D. Safety Operation:

1. The lid must be closed for the centrifuge to start. The lid safety cam #2286-B will engage a micro switch, completing the initial part of the circuit.
2. When the start button is activated, power is sent to a delay relay, which supplies power to the lid lock solenoid for two seconds.
3. Closure of the lid lock solenoid locks the lid and engages the lid lock micro switch.
4. Power is sent through the emergency stop button to the motor contactor, starting the motor.
5. The residual energy module, (R.E.M. #25540) senses motor rotation and holds the lid lock solenoid energized while the motor is turning. This safety must operate to continue to keep the lid locked. If it does not, the delay relay will de-energize after two seconds, releasing the lid lock solenoid and its associated micro switch, turning the machine off.

## **TOOLS**

The tools and test equipment required for routine maintenance and most repairs for your NSEP centrifuge are as follows:

- 1 ea. - Open end wrenches (1/4" to 1")
- 1 ea. - Hex head Allen wrenches (1/8", 3/16", and 5/16")
- 1 - 8" Slip joint pliers
- 1 - #6 Slot head screwdriver
- 1 - #2 Phillips head screwdriver
- 1 - Grease gun designed to fit 5/16" grease fittings and medium weight lithium grease
- 1 - Socket wrench set from 1/4" to 1" (3/8" or 1/2" drive)
- 1 - Adjustable wrench (crescent type) with capacity up to 1-1/2"
- 1 - 16 oz. Claw or ball peen hammer
- 1 - Rubber mallet or lead hammer
- 1 - Set of feeler gauges to use at .070 to .090 inches (must fit through 1/2" hole to gauge runner gap)
- 1 - 1/2" Brass drift
- 1 - 3/16" Brass drift
- 1 - VOM or AMP meter

## **WARRANTY**

Warranty information is contained on last page of this manual, please read for details.

If a warranty situation occurs, contact the factory directly (419 726-2645). You must provide the serial # of your FP-90 when warranty is involved.

## PREVENTIVE MAINTENANCE

These schedules will vary depending on use of machine. If used often, accelerate schedule accordingly.

### **ALWAYS REMOVE POWER FROM MACHINE BEFORE PERFORMING ANY MAINTENANCE.**

1. Every 5 days or 15 hours of operation during the first 30 days of service, or when a new brake shoe is installed:
  - a. Adjust brake for wear on the brake shoe with 2307 brake screw. See INSTRUCTIONS FOR ADJUSTING BRAKE section, further back in this manual, for details. This procedure is for the electric solenoid brake system. Every 60 days, turn off power to machine. Check to verify that brake is adjusted properly.
  - b. If braking system is an air brake, system is self adjusting. Still, visually inspect air brake system every 40 hours for wear on brake shoe. Lubricate at grease fittings.

Every 60 days turn off power to machine and ...

1. Remove basket. See step A of service manual for details.

Inspect #3588 stainless steel ball cap for wear (replace if necessary). Inspect hex basketball for wear or rounding of corners of hex ball, (replace if necessary). If basketball is worn or rounded, inspect inside of center post for rounding of corners, (replace if necessary). Lubricate hex basketball and ball cap with medium weight lithium grease.

2. Remove the 3 fasteners securing the curb (outer stainless shell) to the base. Lift off the curb. See step D of service manual for details.
3. Inspect brake shoe lining, if brake lining is worn to within 1/8" of shoe replace with new brake shoe, (the rivets may score the hub, replace worn shoe at once to avoid damage to the brake hub). See step J of service manual for details.
4. Lubricate brake shoe and brake arm (2306) at lube points with medium weight lithium grease. See step K of service manual for details.
5. Inspect trunnion rubbers and bumper rubbers for wear (replace if necessary). See step G of service manual for details.
6. Inspect pulleys on motor and center unit for wear or rounding out of belt drive area, (replace if necessary). See step G and M of service manual for details.
7. Inspect drive belt for wear and proper belt tension (belt should be as loose as possible without slipping on start-up). Replace and adjust as necessary. See step L of service manual for details.
8. Re-install curb. See step E of service manual for details.
9. Lubricate #3588 ball cap and hex ball, then place basket gently on basketball. See step B of service manual for details.
10. Remove 2291SS control panel cover, (POWER SHOULD BE OFF TO MACHINE BEFORE ENTERING THE CONTROL BOX). See step N of service manual for details.

11. Lubricate 22540 lid lock lever with medium lithium grease.
12. Lubricate 2399-B lid hinge brake with medium weight lithium grease.
13. Test the fall of the lid. It should not fall freely. Adjust 23980 hex cap screw to control fall of lid. See step Q of service manual for details.
14. Adjust lid lock lever adjusting screw #22560 if the lid can be raised above recessed area in curb assembly. See step R of service manual for details.
15. Inspect labels on machine. Replace any worn labels.

### **SUMMARY OF SAFETY INFORMATION**

Basic safety for your NSEP centrifuge includes these important points:

1. Keep all safety and brake components adjusted to factory specifications.
2. Perform the scheduled or preventive maintenance on a regular basis.
3. Never force the lid of the machine open.
4. Use the emergency stop button if needed to stop the machine.
5. Always disconnect the power to the machine before performing any maintenance.
6. Maintain all labels in good readable condition. Contact NSEP for replacement labels.
7. Put the machine out of order and disconnect the power if any unsafe condition arises.
8. Never defeat or bypass any of the safety systems built into the machine.

## SAFETY TESTS:

Perform these simple safety tests every 30 days to check the safety systems of you machine. If any problems develop between tests take the machine out of service, disconnect the power to the machine and repair the cause of the malfunction.

Every 30 days:

### 1. LID BRAKE TEST:

Open the lid, so that it is 18 inches from the curb top, and then test again at 8 inches from the curb top. It should not fall freely, but should stay in place in both positions. If the lid closes by itself from either position tighten the lid brake adjusting screw (2398), until the lid will not fall on its own from either position.

### 2. LID LOCK TEST:

Start the machine and try to lift the lid. The lid should be locked. If the lid can be lifted more than 1/2" above the recessed area of curb, adjust the lid lock adjusting screw as follows: loosen the jam nut (25560) and turn the adjusting screw (2256-B) 1/2 turn counter clockwise. Tighten the jam nut. Again start the machine, and attempt to open the lid. If the lid can be opened more than 1/2" repeat adjustment procedure. Once the lid has been adjusted so that it will not open 1/2" while machine is running check to be sure that the adjusting bolt (2256-B) is not binding on the lid lock cam (2253-B). The lid lock solenoid (51280 or 51290) must be able to close completely. If the solenoid cannot close completely, it will make a loud humming noise. If after repeated attempts, the lid lock cannot be adjusted, check the lid lock cam (2253-B) for cracks and the keyways on the shaft (32080) and cam (2253-B) for wear.

NEVER attempt to run the centrifuge if the lid lock cannot be adjusted or any component is broken or disconnected, put the machine out of service and contact NSEP Service Department at (419) 726-2645.

### 3. EMERGENCY STOP TEST:

Start the machine. After one minute, press the emergency stop button and record the time it takes from when the button is depressed until the lid releases. If it takes longer than 60 seconds, adjust the brake as outlined in the brake adjustment section of this service manual. If the brake cannot be adjusted so that the lid releases in 60 seconds, check the lining thickness on the brake shoe. When the lining is less than 1/8", replace the brake shoe. If the lid lock never releases or the lid can be opened while the basket is turning, put the machine out of order, disconnect power to the machine and call NSEP Service Department a (419) 726-2645.

### 4. MICRO SWITCH TEST:

Disconnect power to machine. Remove control panel. Inspect the mounting plates for both the lid closed micro and the lid locked micro (K-221), to be sure that the mounting screws are tight. Close the lid. The lid closed cam (2286-B) should strike the micro switch arm so that a "click" is heard when the contact points close inside the micro switch. The closure of the contact points can also be verified by testing the continuity

across the micro switch terminals. Close the lid. Depress the lid lock lever (2254-1) behind the lid lock cam (2253-B). When fully depressed, the lid lock lever (2254-1) should strike the micro switch arm so that a "click" is heard when the contact points close inside the micro switch. The closure of the contact points can be verified by the continuity across the micro switch terminals. After adjustment, be certain that neither the lid lock lever (2254-1) or the lid closed cam (2286-B) or the micro switch arm is able to strike the plastic body of the micro switches.

5. CHECK GUARDS AND PROTECTIVE COVERS:

Inspect the belt guard cover, the control panel cover, and the motor fan cover, to be sure they are in place and secure.

## SERVICE MANUAL FOR FP90

INTRODUCTION: This manual provides specific step by step instructions to assist in repairing and replacing specific parts of your machine. It is designed to be used in conjunction with other materials including, parts list, parts manual, electrical diagram, brake assembly bulletin, trouble shooting guide, preventative maintenance schedule and the summary of safety information. Together, they provide adequate information to repair most of the machine.

ALWAYS TURN OFF POWER TO MACHINE BEFORE PERFORMING ANY SERVICE.

### SERVICE MANUAL TABLE OF CONTENTS

TO REMOVE BASKET-----	A
TO REPLACE BASKET.....	B
TO REPLACE STAINLESS STEEL BALL CAP (3588) .....	C
TO REMOVE CURB .....	D
TO REPLACE CURB .....	E
TO REPLACE BRAKE SOLENOID.....	F
TO REMOVE OR REPLACE CENTER UNIT, TRUNNION RUBBERS, BUMPER RUBBERS, TRUNNION CAPS, BUMPER CAPS, PULLEY, PULLEY HUB, AND TRUNNION FRAME ASSEMBLY .....	G
TO REPLACE TRUNNION FRAME ASSEMBLY .....	H
TO RE-INSTALL CENTER UNIT.....	I
TO ADJUST THE BRAKE OR REPLACE THE BRAKE SHOE.....	J
TO LUBRICATE BRAKE SYSTEM .....	K
TO REMOVE OR REPLACE BELT GUARD, BELT, BELT TENSION SPRING, AND ADJUST BELT TENSION .....	L
TO REPLACE MOTOR, MOTOR PULLEY AND MOTOR PULLEY HUB .....	M
TO REMOVE AND RE-INSTALL CONTROL PANEL COVER .....	N
TO REPLACE LID SOLENOID.....	O
TO ADJUST OR REPLACE MICRO SWITCHES (K-221).....	P
TO LUBRICATE AND ADJUST LID HINGE BRAKE .....	Q
TO LUBRICATE AND ADJUST LID LOCK LEVER.....	R
TO REPLACE LID HINGE, LID CLOSED LEVER, LID HINGE FRAME, LID HINGE BRAKE, AND LID LOCK CAM.....	S
TO REPLACE TIMER.....	T
TO REPLACE OTHER ELECTRICAL PARTS .....	U

## **NSEP SERVICE MANUAL FOR FP-90 FLUID DRIVE MODEL**

### **A. TO REMOVE BASKET:**

1. CAUTION: Basket is heavy (300 + LBS. empty). You will require assistance to remove the basket.
2. Raise lid, secure from falling if necessary.
3. Basket can be lifted straight up and out of machine, no tools are needed. FP90 models have lifting yokes for baskets. Do not get fingers, etc., between curb sidewall and basket. Do not drop basket.

### **B. TO REPLACE BASKET:**

1. CAUTION: Basket is heavy, use lifting yoke and overhead hoist.
  - A. Before replacing basket:
    1. Inspect (3588) ball cap for wear - replace if necessary.
    2. Inspect corners of hex ball, if they are rounded - replace hex ball. If hex ball is damaged, inspect inside of center post of basket for basket.
  3. Grease top of hex ball with medium weight lithium grease. Failure to do so may result in excessive vibration and/or excessive wear to center post and hex basketball.
  4. Examine your drain to be certain it is not blocked.
2. Place the basket gently on the hex basket ball. Do not drop basket. Rotate the basket by hand until it engages the hex ball and falls into position.
  - A. If after removing and replacing basket - some vibration occurs - try basket in another position on the hex basket ball (6 positions possible).

### **C. REPLACE STAINLESS STEEL BALL CAP (35880):**

1. Remove basket as per step A.
2. Remove Phillips head screw in center of ball cap (Phillips screw threads into the end of shaft to secure ball cap). Use a screwdriver underneath edge of 35880 to pop it off. It snaps into and out of place.
3. To replace, place in proper position and use a rubber mallet to snap down into hex ball. Replace Phillips screw through center of ball cap and thread into shaft.
4. Lightly grease top of hex ball with medium weight lithium grease.
5. Gently replace basket as per step B.

### **D. TO REMOVE CURB:**

1. Remove basket as per step A.
2. Remove 3 fasteners on inside of curb that secures curb to skirt legs.
3. Remove curb (if stuck, simply rock to break loose glue on rubber mounts).

#### **E. TO REPLACE CURB:**

1. Inspect gaskets on legs, replace if necessary.
2. Replace curb on skirt assembly and align holes.
3. Replace the 3 fasteners to fasten curb to skirt. Hand start fasteners with gasket and bent washers (gasket against curb).
4. Tighten the 3 fasteners in a clockwise fashion. Do not over-tighten.
5. Put lid down and check lid/curb alignment.
6. If curb and lid are not properly aligned, tighten appropriate curb fastener to refine alignment.
7. Do not tighten bolts so tight that you bend the curb.
8. Replace basket as per step B.
9. Check outside of curb for leaks after first use.

#### **F. TO REPLACE BRAKE SOLENOID:**

1. Turn off power to machine.
2. Remove basket and curb as per steps A and D.
3. Remove wires and insulation at brake solenoid (mark and replace in same position).
4. Remove solenoid shield.
5. Remove brake solenoid mounting screws.
6. Remove pin in brake solenoid plunger (remember how it was connected).
7. Replace brake solenoid (check voltage).
8. Replace linkage and pin.
9. Depress solenoid plunger and check brake adjustment as per step J.
10. This is a good opportunity to inspect and replace (trunnion and bumper rubbers, brake shoe and lubricate brake pins). See steps J, K, and G.
11. Replace wires to brake solenoid and re-insulate terminals.
12. Replace curb and basket as per steps E and B.

#### **G. TO REPLACE CENTER UNIT, AND/OR TRUNNION AND BUMPER RUBBERS, BUMPER TRUNNION CAPS, PULLEY AND TRUNNION RING ASSEMBLY.**

1. Remove basket and curb as per steps A and D.
2. Remove the two trunnion caps (2 bolts per cap). Note that lip on underside of cap is toward outside of machine. Replace the same way when reassembling.
3. Remove wires at brake solenoid (mark wires so they can be replaced the same way).
4. Remove drive belt per step L.

5. Lift center unit straight up out of skirt and set aside. (CAUTION: this unit weighs approx. 150 lbs).
6. To change pulley sheaves and/or pulley on center unit:
  - A. Remove unit as per step G, 1-5.
  - B. Remove threaded fasteners in pulley sheaves and replace with new sheaves.
  - C. To remove pulley hub from shaft, remove set screws and pull off of keyed shaft.
  - D. Replace pulley hub and pulley sheaves in same position as per old pulley. (When unit is back in place, the unit pulley and the motor pulley should be in the same plane).
  - E. Reinstall center unit as per step I.

#### **H. TO REPLACE TRUNNION RING:**

1. Remove trunnion ring as per step G.
2. Slide 3 bumper rubbers onto square ends of trunnion hangers.
3. Place trunnion ring in hangers on machine base (they will only fit properly one way).  
Check that the bumper rubbers are properly seated in the hangers. If not consult factory.
4. Replace the 3 bumper caps (be sure that lip on the under-side of the bumper cap is toward the outside of the machine). Hand start the bolts.
5. Tighten bolts securely.

#### **I. TO RE-INSTALL THE CENTER UNIT:**

1. Remove the center unit as per step G.
2. Replace center unit into trunnion ring with brake solenoid in back right side (opposite motor).
3. Replace trunnion caps as they were before you removed the center unit. (Lip on underside of cap goes toward outside of machine.)
4. Hand start bolts.
5. Tighten bolts securely.
6. Test movement of center unit.
  - A. Stand at left front of machine and rock the top of the shaft away from and toward you. The top of the shaft should move about 1/2" off center.
    1. If too loose or tight, shim accordingly or call factory for service.
7. Reconnect wires on brake solenoid as they were.
8. Replace drive belt as per step L.
9. Replace curb and basket as per steps E and B.

#### **J. TO REPLACE BRAKE SHOE:**

1. Remove basket and curb as per steps A and C.

2. Remove and save the two snap rings (2314) and nylon washers on top on the brake pin studs with a screwdriver.
3. Depress brake solenoid plunger to relieve tension on shoe.
4. Brake shoe now pulls straight up off of pins.
  - A. If stuck, tap lightly upward on both sides of the shoe using soft metal or wood.
  - B. Move linkage around to lessen tension on shoe.
5. After old shoe is removed, clean old dirt and grease from brake pins. Lightly grease sides of pins with medium weight lithium grease.
6. Install new brake shoe on brake pins, with casting number facing down on 2400-280 brake (casting #2400-271).
  - A. Adjust linkage with solenoid plunger to align pins with holes in brake.
  - B. Adjustment may be needed on 2307 bolt to fit new shoe on.
  - C. Tap new shoe straight down on pins with rubber mallet.
  - D. Replace nylon washers and snap rings (2314). Pliers work best on snap rings.
  - E. Adjust brake with 2307 adjusting screw.
    1. Manually press in solenoid plunger and turn brake hub.
    2. If brake hub turns freely, use 1/2" open end wrench to loosen the lock nut off 2307 screw (counter clockwise) until brake shoe just touches brake hub.
    3. Now turn the 2307 adjusting screw (clockwise) until brake hub just turns freely (about 3/4 of a turn).
    4. If brake is adjusted correctly the solenoid plunger will travel only 3/8" to 1/2" to release the brake.
  5. Tighten lock nut to hold 2307 screw in place.

NOTE: Brake will need more frequent adjustment during the first 30 days of operation, or when a new brake is installed.

6. Lube the 3 grease fittings on the brake assembly. One on the 2306 brake adjusting arm and two on the brake shoe. See INSTRUCTIONS FOR ADJUSTING BRAKE section for details.
7. Reinstall curb and basket as per steps E and B.

#### **K. TO LUBRICATE BRAKE SYSTEM:**

There are two grease fittings on either end of the brake shoe. The third grease fitting is located on the 2306 brass brake adjusting arm. To grease the brake shoe and adjusting arm remove basket and curb as per steps A and C. The brake shoe and adjusting arm should be greased every time the curb and basket is removed for any maintenance. See INSTRUCTIONS FOR ADJUSTING BRAKE section for details.

**L. TO REMOVE OR REPLACE BELT GUARD, BELT, BELT TENSION SPRING AND ADJUST BELT TENSION.**

1. Belt guard is held down with 1 hex head cap screw. Remove cap screw and slide guard away from machine and free of motor shaft.
2. Pull motor hanger away from machine to relieve tension on 2400-285 belt tension spring, then flip 2167 belt tension bolt away from hanger 2400-337. Remove old belt.
3. Belt can now be replaced. Put belt on center unit pulley, then on motor pulley.
4. Pull motor hanger 2400-337 away from machine beyond the length of the 2400-285 spring and flip 2167 bolt into place.
5. Do not over tighten belt. It should be as loose as possible without slipping. If too tight: shorten 2400-285 belt tension spring. If too loose: shim out spring with flat washers.

**M. TO REPLACE MOTOR OR MOTOR PULLEY:**

1. Remove drive belt as per step L.
2. If changing pulleys only skip to step 5.
3. Disconnect conduit from splice box on motor. Disconnect wires from motor, mark wires for reconnection. See electrical diagram for details and wire locations.
4. Motor and motor hanger can now be lifted straight up and be removed.
5. If changing pulleys only, disconnection of wire and conduit, simply lift motor and hanger until hinge pins are free and turn motor on its side.
6. To replace pulley sheaves and/or pulley hub from motor:
  - A. Remove bolts through pulley sheaves and remove old pulley sheaves.
  - B. To remove pulley hub (does not need to be removed to replace sheaves only), remove set screw and slide pulley hub past key and off of end of shaft.
  - C. To replace pulley hub, position shaft and key, tighten set screws.
  - D. To replace pulley sheaves, hand start the four bolts through the sheaves, then tighten securely.
  - E. To replace pulley hub, position shaft and key, tighten set screws.
  - F. To replace pulley sheaves, hand start the four bolts through the sheaves, then tighten securely.
7. If you are replacing the motor with a NSEP replacement motor, follow this simple procedure: the new motor will come with motor hanger, pulley hub and pulley. Simply slide motor hanger hinge pins into place, then reconnect wires to motor splice box the same fashion they were removed. See wiring diagram in owners manual.
8. Replace the belt, belt tension spring (2400-285) and belt guard as per step L.

**N. TO REMOVE AND REINSTALL CONTROL PANEL COVER, 2291 (ON BACK OF MACHINE).**

TURN OFF POWER TO MACHINE BEFORE REMOVING COVERS.

1. To remove 2291SS, remove the 12 hex head screws from back panel. (If back panel is stuck on box lightly pry loose at gasket.
2. To replace 2291SS, hand start all screws, then tighten in an even manner until gasket compresses and seals.

**O. TO REPLACE LID SOLENOID:**

1. Remove control panel (2291SS) per step N.
2. Remove pin and spacers in lid solenoid plunger.
3. Remove wires on solenoid (mark and replace in same place on new solenoid).
4. Remove the four screws holding lid solenoid to control panel.
5. Replace solenoid (check voltage, be sure replacement solenoid matches control voltage.)
6. Install lid solenoid link, spacers, and pin.
7. Depress lid solenoid plunger until completely shut.
8. Check micro switch adjustment:
  - A. Micro switch arm should close and click shut, but should not hit the black plastic body of the switch.
    1. Lid solenoid has some up and down adjustment.
    2. Micro switch mount plate has some up and down adjustment.
9. Replace wires on solenoid spades. See wiring diagram if unsure of placement.
10. Turn on power to machine and test run through a cycle to be sure lid solenoid and micro switch are adjusted properly.
11. Turn off power and replace control panel as per step N.

**P. TO ADJUST OR REPLACE K-221 MICRO SWITCH:**

1. To replace lid closed micro;
  - A. Remove control panel cover (2291SS) as per step N.
  - B. If replacing lid closed micro, remove mounting plate (2283), mark and remove wires to micro switch, then unbolt and replace micro (do not over tighten bolts through micro or it will crack the body of the micro). Replace the wires identically, reinstall the mount plate, then adjust as per next step.
  - C. To adjust micro- close lid of machine and check that the lid closed cam (NSEP part #2285 or 2285-B) is closing the micro. Be sure the micro switch arm is not hitting the body of the switch.
  - D. Micro switch mount plate can be adjusted up and down and tilted to refine adjustment. Also, lid closed cam (NSEP part #2286-B) can be adjusted on hinge shaft by loosening the set screw. Be sure all screws and set screws are tight when adjustment is completed.
2. To replace and adjust lid locked micro:

A. To replace lid locked micro, remove mount plate (2284), then mark and remove wires (so they can be replaced in identical way). Then, unbolt and replace micro (do not over tighten bolts through micro or it will crack the body of the micro). Replace the wires in identical positions (see wiring diagram if unsure). Reinstall the mount plate then adjust as per next step.

B. To adjust, this micro should close and click shut, but not hit the body of the micro switch when the lid lock solenoid is completely closed.

1. Depress solenoid plunger, if it does not close completely, adjust solenoid up and down on mounting screws.

2. Depress plunger again, micro switch arm should click closed but not hit the body of the micro, (nor should the lid lock lever). Adjust micro by raising, lowering or tilting the mounting plate.

3. Secure all screws.

4. Turn on power and test run machine (if either micro fails to close, the machine will not run).

5. Turn power off and replace control panel cover.

#### **Q. TO LUBRICATE AND ADJUST LID HINGE BRAKE (NSEP PART #2399-B)**

1. To lubricate (scheduled maintenance every 60 days).

A. Remove control panel cover (#2291) per step N.

B. Use a medium weight lithium grease on the 5/16" grease fitting on the hinge brake (part #2399-B). Check lid adjustment.

2. To adjust fall of lid - open and close lid - stop at various distances above the curb. The lid should stay in place by itself. It should not fall freely, but can be pulled shut easily.

A. If too loose or falls too freely - tighten 2398 bolt on lid hinge brake - check lid again, adjust as needed.

B. If lid is too tight, loosen 2398 bolt, check again, adjust as needed.

#### **R. TO LUBRICATE AND ADJUST LID LOCK LEVER (NSEP PART #2254-1)**

1. Remove control panel cover (#2291) as per step N.

2. To lubricate lid lock lever - there is a 5/16" grease fitting on the 2254-1, use a medium weight lithium grease.

3. To adjust lid lock lever.

A. Lid lock lever should fit behind lid lock cam such that the lid cannot be opened more than 1/2" above the curb when lid lock solenoid is closed, (so that fingers cannot be inserted under lid when lid is locked).

B. To adjust-there is a bolt (#2256) with a lock nut, in the end of the lid lock lever.

1. If lid can be opened more than 1/2" when locked, loosen lock nut and adjust bolt until head of 2256-B bolt is as tight against the vertical surface of the 2253-B lid lock

cam as possible, BUT STILL ABLE TO LOCK AND UNLOCK WITHOUT CATCHING OR JAMMING. Adjust as needed, tighten lock nut into place.

2. If lid lock lever cannot close completely, loosen lock nut on adjusting bolt and turn bolt in until lever is just able to close without jamming. (Lid solenoid will buzz or hum loudly if jammed or unable to close completely). Tighten lock nut into place.

3. Operate lid lock lever and solenoid several times and test lid lock adjustment. Then replace control panel cover.

#### **S. TO REPLACE LID HINGE, LID CLOSED LEVER, LID HINGE FRAME, LID HINGE BRAKE AND LID LOCK CAM:**

1. Remove control panel cover (#2291SS) as per step N.
2. Loosen set screw on lid closed lever and lid lock cam, slide lid lock cam toward outside of box, remove key from hinge shaft.
3. Remove lid hinge brake adjusting bolt (#2399B), save this bolt.
4. Remove nuts from bolts through lid hinge frame, then remove two bolts through end of lid hinge frame. (CAUTION: Use 3/16" brass rod or soft metal to drive bolts out so that you do not flare out the ends of the bolt or damage the threads.
5. Use a 1/2" brass rod or other soft metal (so as not to flare out end of hinge shaft) to drive the lid hinge shaft slowly through the hinge frame and control box, being sure that it is not hung up on hinge frame or lid hinge brake.
6. If replacing lid lock cam or lid closed lever only, remove hinge shaft enough to slip off old piece and slip on new piece.
7. Slide new (or old) lid hinge shaft through the lid hinge frame and into the control box (check to be sure nylon washers are between lid hinge frame and control box). Use a brass or other soft metal to pound on lid hinge shaft to prevent flaring out end of shaft. (There may be water-proofing rubber washers (2400-149G) glued to the side of the control box with contact cement. Be sure these are not loose- use some grease on the hinge shaft to slide through these washers. Replace and re-glue if broken free from box.
8. Replace lid closed safety lever, lid hinge brake, and lid cam on shaft before going through opposite side of control box.
9. Be sure nylon washers are in place between lid hinge frame and control box.
10. Center new hinge shaft.
11. Install key in lid hinge shaft and slide lid lock cam over key and lock set screw in place.
12. Close lid of machine and turn hinge shaft so that flat surface of lid lock cam is vertical- so that when the lid lock solenoid is closed, the lid lock lever is locked behind the lid lock cam.
13. Reinstall and/or tighten (2398) bolt through lid hinge brake to lock the lid hinge shaft in place (so that it will not turn while drilling new holes in hinge shaft).
14. Double check lid lock cam positioning - be sure it is correct.

15. Drill the new holes straight down through the lid hinge (if needed) and lid hinge shaft (use sharp 1/4" or D drill).
16. Install the new lid hinge bolts and nuts securely.
17. Adjust the lid hinge brake so that the lid will close but not fall freely as per step Q.
18. Adjust the lid lock lever adjusting bolt so that the lid lock lever will close when the lid lock solenoid is closed and the lid cannot be opened more than 1/2" above the curb when locked as per step R.
19. Adjust lid closed cam (2286-B) so that lid closed micro is closed, then tighten into place with set screw as per step P.
20. Test run machine several times and double check all adjustments.
21. Replace control panel cover as per step N.

**T. TO REPLACE TIMER:**

1. Outside timer (2446 or 2447 (analog), 38098 or 38099 (digital)) on side of control box.
  - A. Unscrew slot headed screw on face of timer.
  - B. Lift handle up until timer is released and can be pulled out of control box.
  - C. Reverse procedure to install replacement timer. (Inspect pins & sockets on timer & inside case to see if plastic mounting case needs to be replaced.)
2. Inside timer:
  - A. Turn off power to machine.
  - B. Remove control panel as per step N.
  - C. Mark and remove wires to timer.
  - D. Remove the mounting screws holding timer to control panel.
  - E. Install new timer, reconnect wires to identical positions on new timer. (Double check voltage on replacement part).
  - F. Set timer for desired length of cycle.
  - G. Replace back panel cover and test run machine.

#### **U. TO REPLACE OTHER ELECTRICAL PARTS:**

1. TURN OFF POWER to machine.
2. Remove control panel cover as per step N.
3. Mark and remove the wires leading to the part (so wires can be replaced identically on the new part).
4. Remove the screws (or other fasteners) holding the part to the control panel and remove old part.
5. Check voltage of replacement part to be sure it is the same as your CONTROL voltage.
6. Install new part in control panel and replace wires in the same position as on the old part (see wiring diagram for details).
7. Test run machine, then replace control panel cover as per step N.

## ELECTRICAL CONTROL PANEL PARTS

<b>PART #</b>	<b>DESCRIPTION</b>
26210	START BUTTON
26240	START BUTTON RUBBER BOOT
29640	LIGHTED STOP BUTTON
K-221	(2) MICRO SWITCH
51280	LID LOCK SOLENOID
22460	240 VOLT 0-10 MINUTE ANALOG TIMER
38099	240 VOLT DIGITAL TIMER
22470	120 VOLT 0-10 MINUTE ANALOG TIMER
38098	120 VOLT DIGITAL TIMER
54311	MOTOR CONTACTOR (220V)
24500	TIME DELAY RELAY
24180	TERMINAL BLOCK
54220	BRAKE SOLENOID (FOR ELECTRIC BRAKE SYSTEM ONLY)
25540	REM

## **FP90 DRIVE UNIT ASSEMBLY AND DISASSEMBLY**

The hex basketball is a press fit on the square at the top of the shaft. First remove the Phillips head screw, located at the top of the stainless steel ball cap. The hex ball and hex basketball is now ready to be removed. It will be necessary to drive this casting off the shaft, using a lead hammer if possible, or by protecting the casting with a piece of wood when driving it off with a hammer. Next, remove the rubber shaft seal which covers the upper shaft nut. Lay the drive unit on its side and loosen the pipe plug in the oil housing. Do not completely remove the pipe plug, since the oil would escape, but it is most convenient to loosen it before further disassembly. Now loosen the two

Allen set screws in the upper shaft nut, loosen and remove the shaft nut. Loosen the two set screws on the brake hub.

If it is not possible to lift the hub off the shaft, it may be necessary to drive the hub off as follows: Since the hub is keyed on the shaft, it is necessary to drive the hub straight along the vertical axis of the shaft. First remove the bottom cover and oil can assembly. Then, remove the six cap screws securing the bottom end cover to the outer housing and turn the entire unit upside-down. Place a board on the floor to protect the end of the shaft. Now, using the weight of the drive unit and grasping the drive unit by its trunnion, thump the end of the shaft on the board to assist in driving the brake hub off the shaft itself. This action should drive the hub and the top end cover with bearing off the shaft and drive unit assembly. While driving this assembly off the shaft, observe the shaft key so not to damage the bearing while driving it off.

To remove the bearing from the top end cover, remove the three cap screws securing the bearing cap to the top end cover. At this time, the brake shoe should be removed so the bearing can be removed. Now turn the top end bell over and drive the bearing out, using a heavy drift along the inner edge of the bearing which will be exposed when turning over the top end cover assembly.

To remove the bottom bearing only, it is not necessary to go through the above procedure, since it can be removed from the bottom of the drive unit as follows: Remove the cap screw and washer at the bottom of the shaft end of the drive unit. Now remove the four cap screws securing the pulley sheaves to the pulley hub. Remove the two set screws in the pulley hub and pry the pulley hub off the shaft. Remove the square key. Now remove the six cap screws securing the bottom end cover to the drive unit housing. With the drive unit in an upright position, tap this assembly lightly on the floor to assist in removing the bottom end cover from this assembly. Now that the bottom end cover is removed from the assembly, remove the snap ring securing the bottom bearing to the bottom housing. Using a drift, drive this lower bearing out of the bottom housing, since the bearing edge will be visible from the underside of this housing.

End play in the shaft itself is normal and all adjustments or measurements made on the shaft should be made with the shaft driven fully down, since it is normally used with a heavy basket on the shaft holding it in the full down position.

When assembling the drive unit, remove the pipe plug in the oil chamber with the drive unit laying on its side (with fill plug up so that the oil does not escape). Now start tightening the upper shaft nut until the proper gap setting (.070) between the impellers in the drive unit is reached. The impellers are visible through the oil hole in the oil chamber. It would be necessary to turn the shaft nut clockwise, which will raise the shaft and open up the gap setting to the desired setting. It can be measured with a feeler gauge. Usually, this will result in having one or two threads exposed above the upper shaft nut.

This is intended as a guide only, and should not be interpreted as an accurate setting. After achieving the proper gap setting, tighten the two Allen set screws securely in the brake hub and in the upper shaft nut.

If oil is lost from oil chamber, dump the remaining oil into a measuring device and add enough oil to have a total of 80 oz. in the oil chamber. Caution: Too much oil in the drive unit could cause a severe burden on the motor and could cause motor damage. Too little oil will cause the unit to spin too slowly or not reach top speed.

If, upon disassembly, the shaft is badly scored or worn due to a seized bearing, it will be necessary to replace the shaft. A tight press fit is required on these parts.

## 3210SS DRIVE UNIT ASSEMBLY

<b>PART NUMBER</b>	<b>DESCRIPTION</b>
35880	Stainless steel ball cap
31290	Hex basket ball
2400-211SS	Main unit shaft (Stainless-T303)
2400-216	Upper shaft nut
2400-218	Lower shaft nut (N-08)
2400-219	Bearing lock washer (W-08)
2400-178	Clutch runner key (1/4" key)
2400-226	Brake hub key (3/8" key)
37320	9" cast iron pulley
37330	11" cast iron pulley
2400-149	Pulley hub washer
37280	Pulley hub (1-3/4" bore)
37290	Pulley spacer ring (1-3/4" bore)
2400-208	Bottom end cover
2400-205	Lower main bearing
2400-395	Retaining ring
2400-212	Lower clutch drive housing
2400-213	Clutch driver
2400-214	Upper clutch runner
2400-215	Upper clutch drive housing
20210	3/8" socket pipe plug
2400-204	Top end plate
2400-206	Upper main bearing
33810	Top bearing seal
33820	Seal sleeve
33830	Top bearing cap oil seal
2400-210	Brake hub
2400-223	Lower shaft bushing
2400-224	Clutch bushing
2400-259	"O" ring seal
2400-282	Water seal (shaft)
2400-207	Drive housing
2400-444	Trunnion rubber

**PARTS LIST FOR FOLLOWING PAGE (FP90 STAINLESS STEEL SHAFT UNIT)**



### ***INSTRUCTIONS FOR ADJUSTING BRAKE***

IF MACHINE IS AN AIR BRAKE SYSTEM, IT IS SELF-ADJUSTING.

IF MACHINE IS AN ELECTRIC BRAKE SYSTEM:

1. TURN OFF POWER TO MACHINE.
2. REMOVE BASKET AND CURB.
3. CONSULT PREVENTATIVE MAINTENANCE SECTION BEFORE CONTINUING.
4. MANUALLY PRESS IN SOLENOID PLUNGER AND TURN BRAKE HUB.
5. IF BRAKE HUB TURNS FREELY IN STEP 3, USE 1/2" OPEN-END WRENCH TO LOOSEN LOCK NUT AND BACK OFF 2307 SCREW (COUNTERCLOCKWISE) UNTIL BRAKE SHOE TOUCHES BRAKE HUB.
6. TURN THE 2307 ADJUSTING SCREW (CLOCKWISE) UNTIL BRAKE HUB TURNS FREELY (ABOUT 3/4 OF A TURN).
7. IF BRAKE IS ADJUSTED CORRECTLY, THE SOLENOID PLUNGER WILL TRAVEL ONLY 3/8" TO 1/2" TO RELEASE THE BRAKE.
8. TIGHTEN LOCK NUT TO HOLD 2307 SCREW IN PLACE.
9. REPLACE CURB AND BASKET.

TO REPLACE BRAKE SHOE:

1. REMOVE 2314 SNAP RING AND 2400-99-1 NYLON WASHER ON 2400-275-1 AND 2400-276-1 STUDS.
2. PULL OLD BRAKE SHOE STRAIGHT UP TO REMOVE.
3. CLEAN GREASE AND DIRT FROM STUDS.
4. LUBRICATE STUDS WITH A MEDIUM WEIGHT LITHIUM GREASE.
5. PUT ON A NEW BRAKE SHOE AND INSTALL SNAP RINGS.
6. LUBRICATE 3 GREASE FITTINGS. (OLD STYLE ONLY)
7. ADJUST BRAKE SHOE.

LUBRICATE 3 LUBE POINTS EVERY 3 MONTHS USING MEDIUM WEIGHT LITHIUM GREASE. (OLD STYLE ONLY)

COST-SAVINGS:

1. BE SURE TO REPLACE BRAKE SHOE BEFORE RIVETS SCORE HUB (ABOUT ONCE A YEAR, DEPENDING ON USAGE). BRAKE LINING SHOULD NEVER BE LESS THAN 1/8" FROM BRAKE SHOE.
2. KEEP BRAKE PROPERLY ADJUSTED. THIS WILL INCREASE SOLENOID LIFE AND DECREASE DOWNTIME.

**AIR BRAKE ASSEMBLY & PARTS**

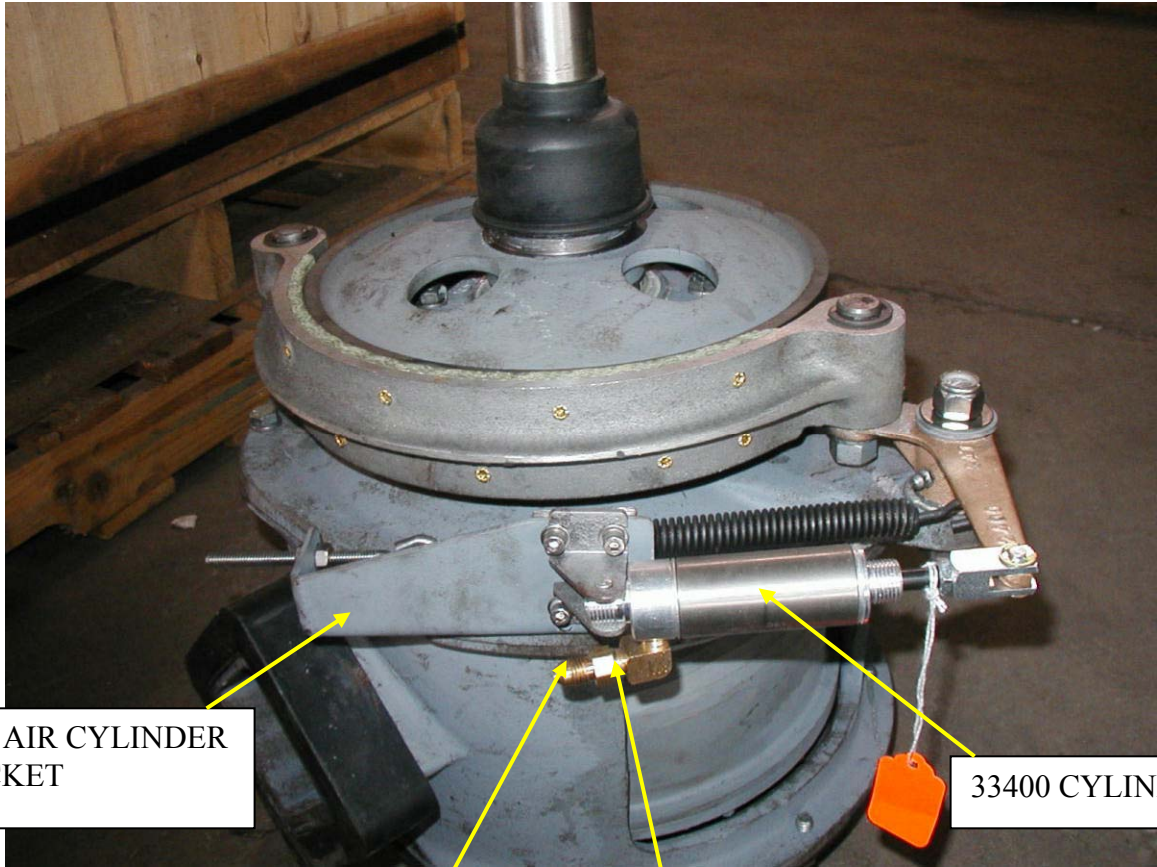

33710 AIR CYLINDER  
BRACKET

33400 CYLINDER

34160 90° ELBOW  
(2) REQ'D

34170 MALE CONNECTOR  
(2) REQ'D

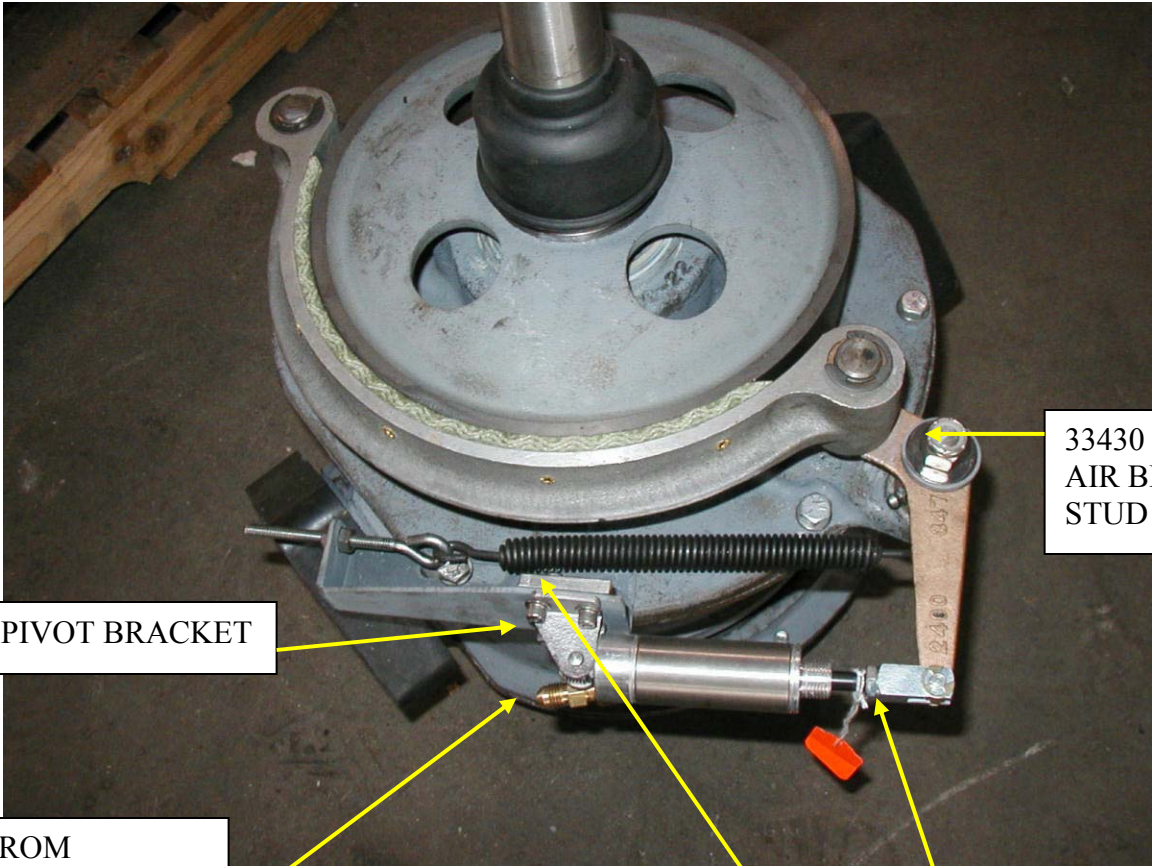

33430  
AIR BRAKE  
STUD PIN

33410 PIVOT BRACKET

HOSE FROM  
SOLENOID VALVE  
CONNECTS HERE

33720 CYLINDER TAP  
PLATE

33420 ROD CLEVIS

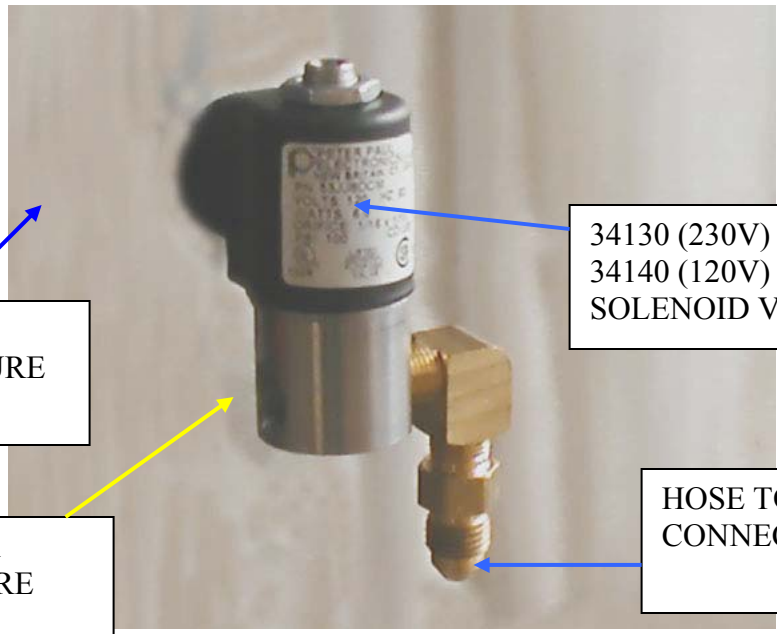

SIDE OF MACHINE  
ELECTRICAL ENCLOSURE

34130 (230V) or  
34140 (120V)  
SOLENOID VALVE

INCOMING AIR  
CONNECTS HERE

HOSE TO BRAKE CYLINDER  
CONNECTS HERE

## TROUBLE SHOOTING GUIDE - MODEL FP90

**PROBLEM:** Machine fails to start, lid is fully closed, start button activated, but machine does not start.

**SOLUTIONS:**

1. Emergency stop pushed in (pull out and restart).
2. Check incoming power supply.
3. Check timer.
4. Check lid closed micro(K-221), check if closed cam (22860) is loose.
5. Check time delay relay (replace).

**PROBLEM:** Lid locks light comes on and motor starts for only 2 seconds, then stops and lid unlocks.

**SOLUTIONS:**

1. Check timer.
2. Lid lock micro switch needs adjustment or replaced.
3. Lid lock solenoid burned out or linkage jammed.
4. REM (25540) malfunction.
5. Lid lock cam (22530) loose or broken.

**PROBLEM:** Machine runs but the basket fails to spin.

**SOLUTIONS:**

1. Drive belt off pulley or belt is broken.
2. Brake may need adjustment.
3. Something wrapped around shaft.
4. Brake not releasing check brake solenoid (if electric brake system), or air brake cylinder (if air brake system). Check brake linkage and spring.
5. Basket not properly engaged on hex ball.
6. Top or bottom bearing failing in fluid drive.
7. Oil quantity in fluid drive (check to see if any oil is on the floor under center unit).
8. Runner gap is not correct inside center unit.
9. Bad bushing in center unit.
10. Drive belt slipping.

**PROBLEM:** Basket fails to accelerate.

**SOLUTIONS:**

1. Brake may need adjustment, brake may not be releasing (check brake solenoid if electric brake system), check brake linkage and spring.
2. Something wrapped around shaft.
3. Oil quantity in fluid drive (check to see if any oil is on the floor under center unit).
4. Runner gap is not correct inside center unit.

PROBLEM: Braking time too long.

SOLUTION:

1. Brake may need adjustment, brake shoe lining worn, check brake linkage and spring.

PROBLEM: Lid stays locked at end of cycle, but machine stops and lid lock light goes out.

SOLUTIONS:

1. Lid lock solenoid burned out or linkage jammed.
2. Lid solenoid spring (3318) is broken.

PROBLEM: Lid stays locked and light stays on, but machine has stopped.

SOLUTIONS:

1. Check timer.
2. REM (25540) malfunction.

PROBLEM: Cycle longer than anticipated.

SOLUTIONS:

1. Check timer.
2. Brake may need adjustment, brake shoe lining worn, also check brake linkage and spring.

PROBLEM: Machine runs in wrong direction (correct rotation should be counter-clockwise).

SOLUTION:

1. Reverse 2 power leads on 3 phase motors.

PROBLEM: Lid falls too freely when open.

SOLUTIONS:

1. Adjust (22560) lid lock adjusting screw.
2. Adjust lid hinge brake.

PROBLEM: Clashing noise during acceleration or rattle during cycle.

SOLUTIONS:

1. Top or bottom bearing is failing.
2. Runner gap in center unit is incorrect.
3. A bad bushing in center unit.

PROBLEM: Basket gets up to full speed immediately.

SOLUTION:

1. Check for correct runner gap in center unit, check oil quantity in fluid drive also.

PROBLEM: Scored brake hub or noise when brake is applied.

SOLUTIONS:

1. Brake shoe lining worn.
2. Check brake linkage and spring.

PROBLEM: Excessive noise or vibration.

SOLUTIONS:

1. Something wrapped around shaft.
2. Basket may not be fully engaged with hex ball.
3. Bad bushing in center unit.
4. Worn shaft.
5. Replace pulleys.
6. Replace bumper and trunnion rubbers.
7. Inspect or replace hex ball and/or center post.
8. Inadequate or loose machine mounting.

PROBLEM: Starting amps excessive.

SOLUTIONS:

1. Something wrapped around shaft.
2. Bearing in unit and/or motor going bad.
3. Belt tension too tight.
4. Check for correct runner gap and check oil quantity in fluid drive.
5. Bad bushing in center unit.
6. Worn shaft.

PROBLEM: Water on center unit.

SOLUTION:

1. Drain restricted.

## PARTS LIST

<b>PART NUMBER</b>	<b>DESCRIPTION</b>
29640	Lighted stop button
26210	Green start push button
26240	Clear rubber boot for 2621
36860	Lid handle (S.S.)
31490	Lid hinge frame (aluminum)
33510	Lid (S.S.)
32460	Curb assembly (S.S.)
35790	Skirt assembly (S.S.)
31490	Lid hinge frame
32760	Lid bumper-rubber
29640	Lighted stop button
26210	Green start button
26240	Clear rubber boot for 2621
32650	Lid bumper angle-S.S.
34840	Gas shock spring (90#)
3484-1	Gas shock spring (120#)
24460	240 Volt, 0-10 minute outside timer
22470	120 Volt, 0-10 minute outside timer
34860	Gas shock spring bracket (spacer)
34130	Solenoid valve (240 Volt)
37180	Coil for solenoid valve (3413)(240 Volt)
34140	Solenoid valve (120 Volt)
37110	Coil for solenoid valve (3414)(120 Volt)
36960	Air condensation bowl
35850	Saddle for control box

## **MOTOR ASSEMBLIES AND ASSOCIATED PARTS FOR FP90**

### **5 H.P. MOTOR ASSEMBLIES**

PART NO. 3215-8	208/60/3 motor assembly*
PART NO. 3215-3	230/60/3 motor assembly*
PART NO. 3215-4	460/60/3 motor assembly*
PART NO. 3215-5	575/60/3 motor assembly*

#### **\*MOTOR ASSEMBLIES INCLUDE:**

5 H.P. motor	Designate voltage required
2400-337	Motor hanger
37340	Motor pulley hub-1-1/8" bore
37320	9" cast iron pulley
23920	1/2" sealtite conduit
23930	ST-9050 1/2" 90 degree connection
24390	Motor fan cover plate
22020	Motor hanger brass pins (5/8"rd X 2.25"lg.)

#### **PARTS ASSOCIATED WITH MOTOR ASSEMBLY**

21680	Tension bolt bracket (cast iron)
21670	Belt tension bolt w/pin (brass)
2400-285	Belt tension spring (replacement spring is longer than needed and will have to be cut to proper length to accommodate the intended belt). A belt too tight will cause bearing failure in drive unit and/or motor.
2400-163SS	Leveling bolt (S.S.) 3/4"-10 X 2" H.H. bolt
2400-164SS	Jam nut (S.S.) 3/4"-10 for 2400-163SS

## ***GLOSSARY***

Actuator	Lever on micro switch.
Adjusting Screw	Bolt in lid lock lever used to keep lid locked onto curb when machine is in operation.
Ball Cap	Stainless cap on top of basket ball.
Basket	Perforated S.S. container inside curb assembly into which material is loaded.
Basket Ball	Cast iron hex part on top the unit shaft, which the basket fits over.
Bumper Cap	Cap used to hold motor in hangers.
Cam	Located inside back panel and keyed onto hinge shaft. Used to lock lid when machine is in operation.
Center Post	The dome shaped part located in the center of the basket into which the unit shaft extends. The purpose is to drive the basket.
Curb	Outer shell of machine in which the basket is housed.
Coil	Electrical device on the motor starter which, when power is applied, switches the starter on.
Contacts	The metal parts of a relay or contactor that the wires attach to which open or close transmitting power within the circuit or to the motor.
Delay Relay	Solid state circuit used to allow current to travel for a certain period of time.
Lid Lock Assembly	Assembly used to keep lid locked when the machine is in operation.
Lid Hinge Brake	Adjustment located on hinge shaft which keeps lifted lid from falling.
Micro Switch	Component used to open and close a circuit.
Solenoid	Electrical component that activates lid lock device.
Skirt	The machine base.
Relay	A device having a coil and one or more contacts which is needed to switch power off and on within a circuit.

# SCHEMATIC DIAGRAM

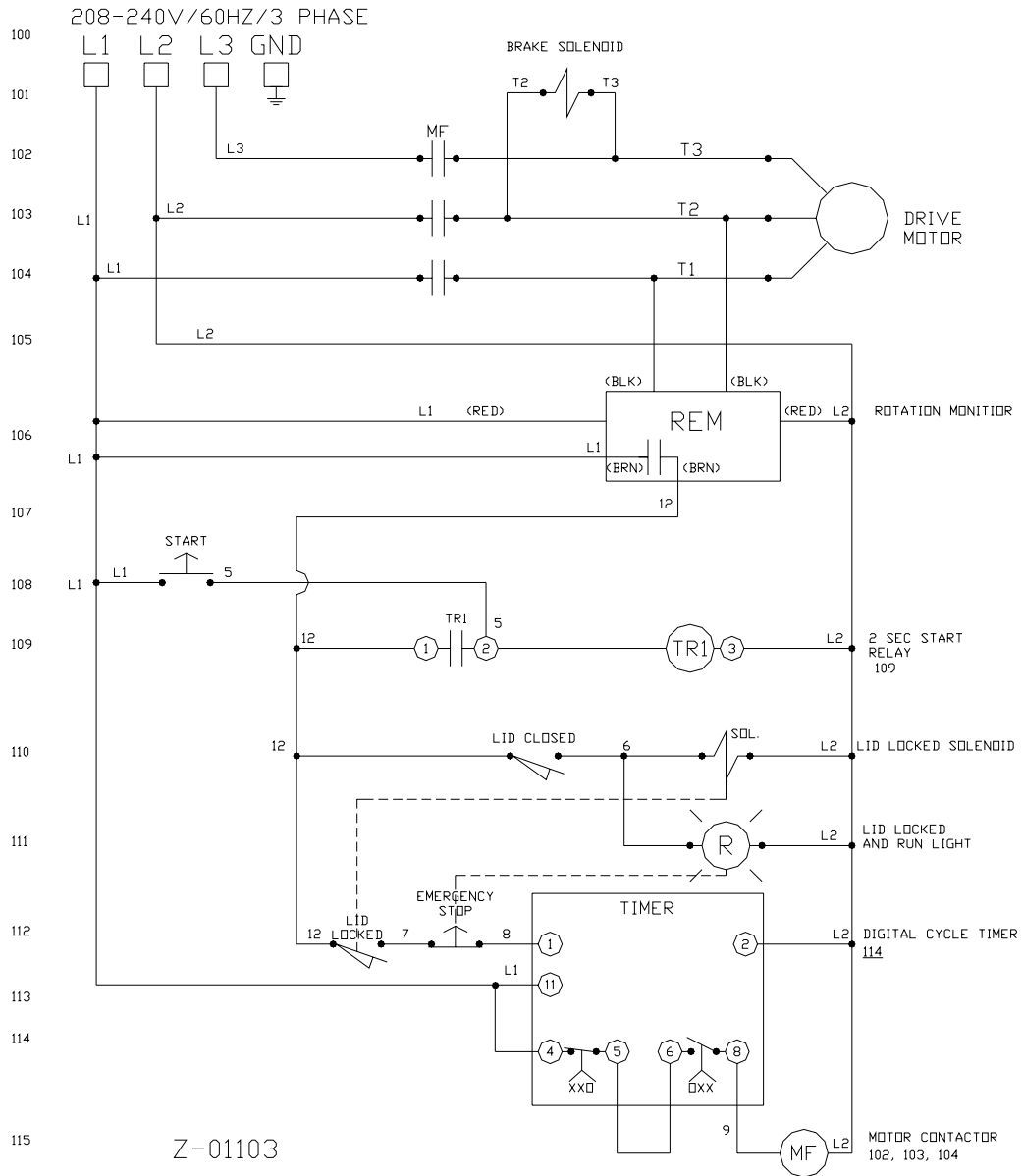

# WIRING DIAGRAM

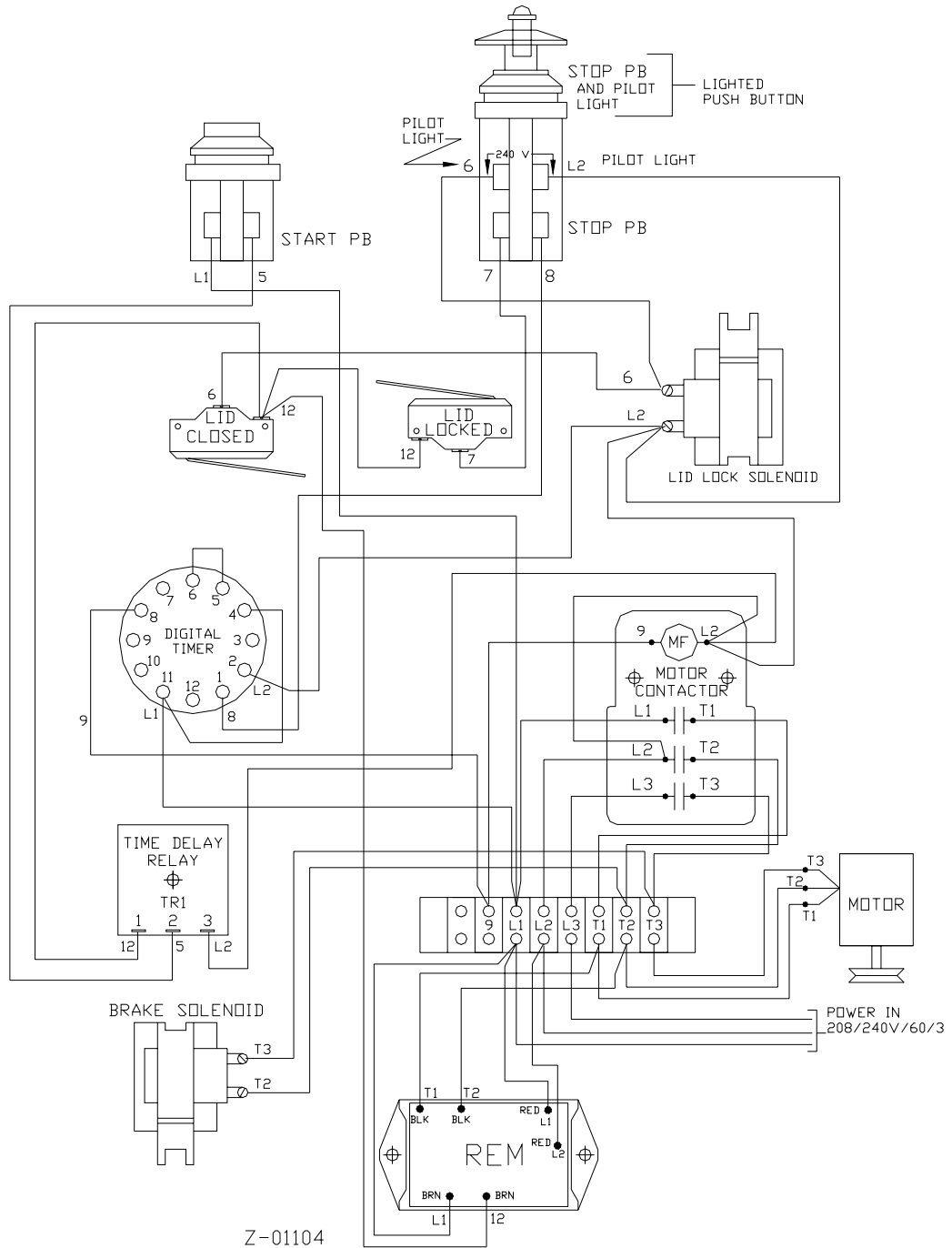

## GENERAL TERMS AND CONDITIONS OF SALE

This agreement sets forth general terms and conditions of sale. The quotation and sales contract may incorporate additional and more specific commercial and technical requirements of sale. The following general terms and conditions are mutually agreed between BUYER and GLASSLINE to be a part of the sales and purchase order documents.

### 1. DEFINITIONS AND GENERAL TERMS AND CONDITIONS

- A. The term GLASSLINE shall refer to Glassline Corporation and all of its affiliated divisions.
- B. The term EQUIPMENT shall refer to any machine, part, product or service sold by GLASSLINE, including subcontracted/purchased items/options.
- C. The term BUYER shall refer to the buying company and, where applicable, its subcontractors.
- D. The terms and conditions set forth in this agreement are effective at the receipt of order by BUYER and are subject to change by GLASSLINE without notice before receipt of order by Buyer.
- E. Quotations are valid for 30 days, unless noted otherwise.
- F. No terms, conditions, understandings, usage of trade, dealings or agreements, purporting to vary, modify, explain or supplement this agreement shall be binding, unless and until hereinafter made in writing and signed by BUYER and GLASSLINE.
- G. This agreement, and its interpretation, shall be governed by the laws of the State of Ohio. If any provision or term of this agreement is held to be invalid, void or unenforceable, the remaining provisions and terms of the agreement shall remain in force and effect, and shall in no way be affected, impaired or invalidated thereby. In all cases, the rights and duties of the parties in a dispute arising out of this transaction shall be governed by the laws of the State of Ohio.
- H. The delegation or assignment by BUYER of any or all of its duties or rights under this agreement without the prior written consent of GLASSLINE shall be void.
- I. Any information, suggestions or ideas transmitted by BUYER or GLASSLINE, or any of their respective representatives, in connection with the performance under this agreement are not to be regarded as secret or submitted in confidence, except as may be otherwise provided specifically in a document signed by a duly authorized representative of GLASSLINE.
- J. This agreement supersedes all previous agreements, written or verbal, and contains the entire agreement between the parties.

### 2. TERMS AND CONDITIONS OF BUYER

Should BUYER have standard terms of acceptance that it wishes to make a part of this agreement, such terms must be provided at the time a quotation is requested and agreed to in writing by GLASSLINE, so that the costs of compliance to such terms as GLASSLINE may agree, if any, may be added to the bid. GLASSLINE reserves the right to quote these compliance features separately and above their standard quotation.

### 3. DELIVERY AND CLAIMS

- A. The quoted shipment schedule is non-binding. The shipment schedule will be set at time of order, and is contingent upon BUYER supplying a clear scope of supply, all technical information, and any required downpayment. A new delivery date may be required, depending on any technical or scope changes requested after the order date, or delays in receiving payments according to agreed dates.
- B. GLASSLINE shall not be liable for delays in delivery caused by any reason beyond GLASSLINE's control, including, but not limited to, force majeure, supplier failure, any interruption of GLASSLINE facilities, or any act of any government, or licensing authority.
- C. Unless otherwise noted in the quotation, all shipments are ex-works GLASSLINE Perrysburg, Ohio plant. BUYER bears all risks of loss or damage to the EQUIPMENT from the time the EQUIPMENT has been placed at the disposal of Buyer at GLASSLINE, whether shipping is arranged by BUYER or on behalf of BUYER by GLASSLINE. In any case, shipments shall be made strictly according to Incoterms 2000.
- D. After the EQUIPMENT is placed at the required transfer point for BUYER, GLASSLINE neither assumes responsibility for nor authorizes any expenses, including electrical work, plumbing, compressed air supply, millwright work, extensions/additions, or materials necessary for the set up and operation of the EQUIPMENT in BUYER's plant or elsewhere. It remains the BUYER's responsibility to meet all federal, state and local codes and regulations.
- E. Claims for shipping damage, concealed or otherwise, are the responsibility of BUYER and should be taken up with the delivering carrier within the stated time allowed for claims. Claims for shipping shortages will not be allowed, unless reported to GLASSLINE within 10 days of shipment.

### 4. TITLE

- A. Title to the EQUIPMENT, thus delivered, shall remain with GLASSLINE; until the full purchase price has been received.
- B. BUYER shall keep the EQUIPMENT fully insured, with GLASSLINE named as loss payee until the purchase price is paid. Neither BUYER nor GLASSLINE shall assign the applicable insurance contact without prior written consent of the other.
- C. Monthly interest, at the rate of 1-1/2% per month on the total unpaid value of the EQUIPMENT will be charged if delivery is delayed at BUYER's request for more than thirty (30) days after buy-off, or if final payment is delayed beyond thirty days (30) after shipment. BUYER shall execute and deliver to GLASSLINE such documents and financial statements as may be necessary to perfect the lien or security interest of GLASSLINE to protect the unpaid balance of the purchase price.

- D. All tools, materials, software, programs, designs, or any technology created for the purpose of producing the EQUIPMENT are the sole property of GLASSLINE, unless furnished by BUYER with the order. All intellectual property created by GLASSLINE shall remain property of GLASSLINE.

**5. WARRANTY**

- A. GLASSLINE warrants against defects in material and workmanship. Items manufactured by others but installed in or affixed to GLASSLINE EQUIPMENT are not warranted by GLASSLINE, but bear only such express warranties, if any, of the manufacturer thereof. GLASSLINE shall replace or repair at its choosing, (ex-works GLASSLINE Perrysburg, Ohio plant) any defective manufactured parts without charge to BUYER. The warranty does not apply to any labor charges for removal and/or replacement, or to any part thereof which has a life, under normal usage, inherently shorter than the warranty period. The warranty will be active for a period of:
  - 1) Machinery: 12 months from date of shipping.
  - 2) Replacement/Repaired parts: 6 months from date of shipping.
- B. Warranty shall be deemed waived by BUYER if:
  - 1) The EQUIPMENT is not properly installed by BUYER, according to GLASSLINE installation instructions.
  - 2) The EQUIPMENT has been subjected to misapplication or misuse, neglect, damaging conditions, or is modified in any way without written approval by GLASSLINE.
  - 3) The production or use of the EQUIPMENT for which it was not intended, or on products out of specification.
- C. The warranty set forth herein is in lieu of all other warranties, whether express, implied or statutory, including those of merchantability and fitness of any product for a particular purpose, and of any other obligation or liability on GLASSLINE's part of any kind or nature whatsoever.
- D. The warranty granted herein is non-transferable, and is granted only to the original BUYER.
- E. No employee, agent or other representative has any authority to waive, alter, vary or add to the terms hereof without prior approval in writing, signed by an officer of GLASSLINE.

**6. LIMITATION OF LIABILITY**

- A. It is expressly understood that GLASSLINE's liability for any damages arising out of or related to this transaction, or for its EQUIPMENT, whether in contract or in tort, is limited to the repair or replacement of the parts thereof as stipulated in the warranty, and is not to exceed the contract price in respect to which the claim is made.
- B. BUYER is solely responsible for ensuring the safety of all personnel who may be in close proximity to the EQUIPMENT.
- C. GLASSLINE will not be liable for any other injury, loss, damage or expense, whether direct, incidental or consequential, including but not limited to labor, loss of use, downtime, loss of material, products income, profit or production, or increased cost of operation, or spoilage of damage to material, arising in connection with the sale, installation, use of, or inability to use, or the repair or replacement of, or late delivery of, GLASSLINE EQUIPMENT.
- D. BUYER shall indemnify, defend and hold harmless GLASSLINE and its directors, officers, agents and employees, against any and all demands, claims, actions, damages, liabilities, costs, expenses (including reasonable attorney fees and expenses) and other losses of any kind whatsoever, whether based upon theories of contract, tort, negligence, strict liability, warranty, indemnification, contribution, statute or otherwise, for personal injury or property damage caused by BUYER or by any of its directors, officers, agents, employees or subcontractors, arising out of or relating to the Equipment Buyer shall give GLASSLINE prompt written notice of any such matters and the full opportunity to defend itself against them. This indemnity of BUYER shall survive the termination of this agreement.
- E. The remedies and limitations set forth in this agreement are the exclusive remedies for claims based upon any defect in or failure of EQUIPMENT, whether products or services, whether such claims are presented in contract or in tort (including negligence) and however and wherever instituted. Upon the expiration of the warranty period, all such liability shall terminate.

**7. ORDER ACCEPTANCE**

GLASSLINE reserves the right to refuse any order. An order shall be deemed accepted and a binding contract formed when the initial payment has been received and the order is acknowledged in writing by GLASSLINE.

**8. CANCELLATION BY BUYER**

BUYER may cancel the order for all or any EQUIPMENT by written notice prior to shipment. GLASSLINE will stop work on the order as soon as possible after receipt of written cancellation. BUYER agrees to pay GLASSLINE for all costs incurred by GLASSLINE and/or other suppliers attributed to the order, including but not limited to components, work-in-process, labor, burden and overhead. Such payment will not transfer title to BUYER.

**9. ARBITRATION AGREEMENT**

Any controversy or claim arising out of or relating to this agreement, or the breach thereof, shall be settled by arbitration in accordance with the rules of the American Arbitration Association and the statutes of the State of Ohio. All hearings held in connection with any such arbitration shall be held in Toledo, Ohio (unless the parties agree otherwise in writing), the award of the arbitrator(s) shall be final and binding upon the parties, and the judgment upon and the award rendered by the arbitrator(s) may be entered in any court having jurisdiction thereof.