



North Star Engineered Products

Item No. _____

MODEL: DT-35

Fruit and Vegetable Dip Tank Style Wash System



The DT-35 is a dip tank style wash system. The entire system is 60.5 gallons with 43.4 gallons in the wash tank, and 17.1 gallons in the recirculation tank. It has start and stop buttons on the control box along with an Emergency stop button. The DT-35 connects to a chiller or is chilled with ice in the recirculation tank. It comes with 2" drains on both main wash tank and also on the recirculation tank. The DT-35 has a wedge wire filter screen over the recirculation tank to remove fines. It features an "On Deck" basket station over the recirculation tank for operator ease of use. Made in the USA.

STANDARD FEATURES

- Great for small jobs
- Matched to fit with FP-35
- Sanitary fittings
- Compact unit
- Accommodates 20 gallon baskets (FP-35)
- Large cleanout drains
- Float switch to protect pump
- Connects to chiller or used with ice
- Perforated lid retains product during cleaning
- 3/8" or 3/16" hole sizes in baskets for optimal cleaning

Types of Applications:

All types of fruits and vegetables, both leafy and root.

Technical Data:

Electrical - 230-460 Volt / 60Hz / 3 phase
 Current: 8 Amp(230V) / 4Amp(460V)
 Motor - 1 1/2 HP pump
 Pump capacity: 100 gallons per minute

Dimensions:

Height: 42 inches
 Depth: 41 inches
 Width: 38 inches
 Basket size: 20 gallon / 35 lb.



North Star Engineered Products
 28905 Glenwood Road
 Perrysburg, OH 43551
www.northstarengineered.com

Phone: (419) 726-2645
Fax: (419) 726-8583
E-mail: sales@northstarengineered.com



MODEL: DT-35 Fruit and Vegetable Dip Tank Style Wash System

UTILITY REQUIREMENTS:

Motor: 1 1/2 HP pump

Electrical: 230-460 Volt / 60 Hz / 3 phase

Current: 8 Amp(230V) / 4 Amp(460V)

Maximum water flow: 100 gallons/minute

SPECIFICATIONS:

- Washes fruits and vegetables in small loads. Keeps fruits and vegetables in cold water to extend shelf life.
- Wedge wire filter over the recirculation tank removes unwanted fines and other small particles.
- Small compact unit makes it easy to put in most working cells.
- Uses 20 gallon mini-brute basket for easy loading/unloading of the DT-35.
- Large open area for easy loading and unloading of baskets.

CONSTRUCTION:

Made with type 304 stainless steel to prevent rust. Comes with 2 inch drains on both main wash tank and also the recirculation tank for quick dump of the wash water.

DESIGN:

Made with an easy to clean manifold, that is attached with sanitary fittings. It can be removed without tools. Wedge wire filter over the recirculation tank ensures the removal of fines and other unwanted products. Large wash area to accommodate 20 gallon Mini-Brute baskets. Designed to work side-by-side with the FP-35 centrifuge. Electrical box is part of the system so there is no need for a separate electrical box.

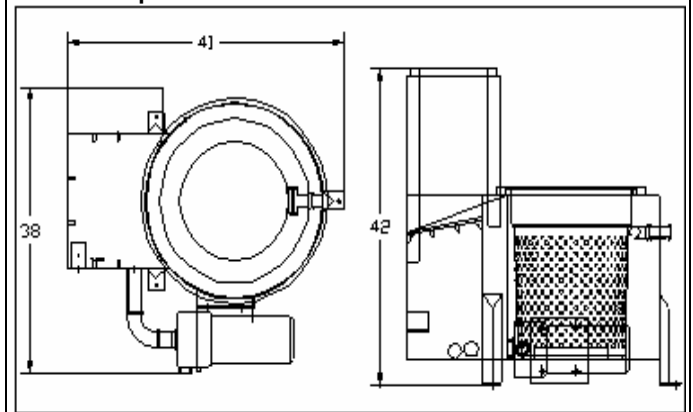

DIMENSIONS:

Height: 42 inches

Depth: 41 inches

Width: 38 inches

Basket size: 20 gallon / 35 lb.

WATER CAPACITY:

17.1 Gallons in the recirculation tank

43.4 Gallons in the wash tank

North Star Engineered Products
28905 Glenwood Road
Perrysburg, OH 43551
www.northstarengineered.com



Phone: (419) 726-2645

Fax: (419) 726-8583

E-mail: sales@northstarengineered.com